



Linea Española

FASCINACION POR LA ARQUITECTURA



SERIE 4600



CORREDERA SERIE 4600

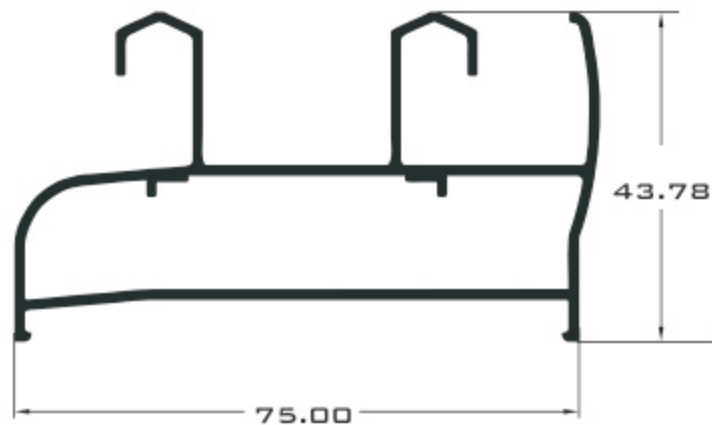

4601 CERCO PERIMETRAL

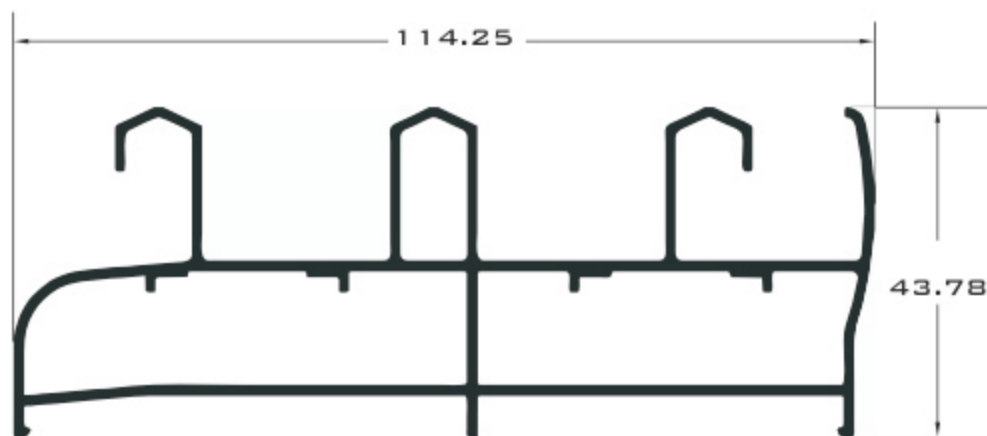

4602 CERCO PERIMETRAL 3 RIELES

ESCALA 1:1

LONGITUD: 6.10 mts.



CORREDERA SERIE 4600

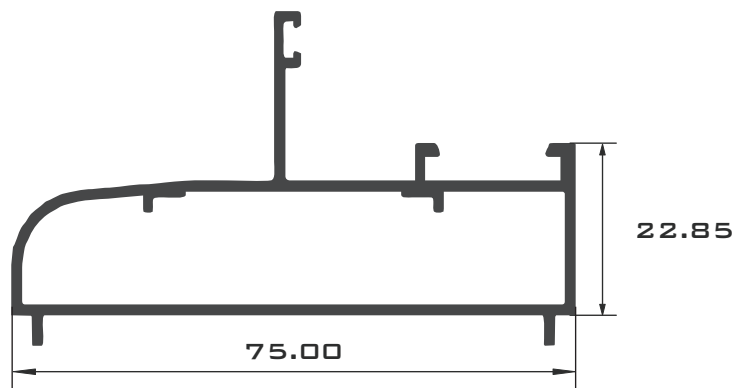

4603 FIJO TUBULAR

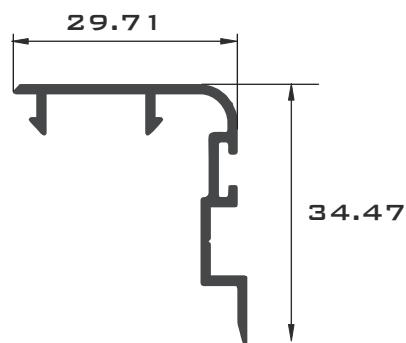

4604 TAPA HOJA CENTRAL

ESCALA 1:1

LONGITUD: 6.10 mts.



CORREDERA SERIE 4600

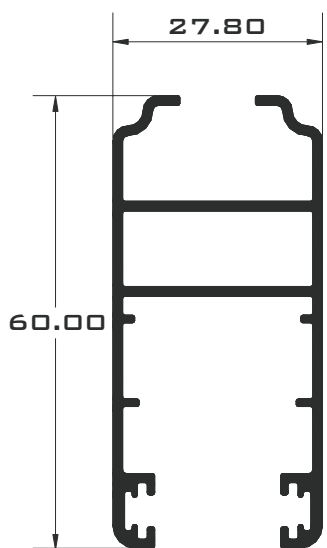

4605 HOJA PERIMETRAL

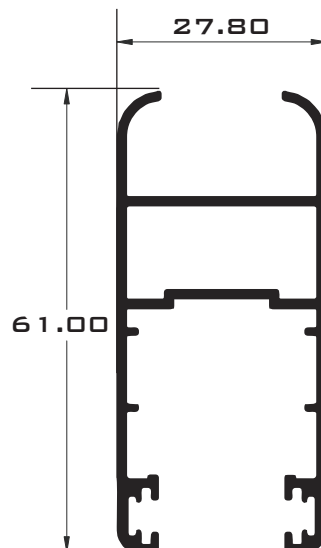

4615 HOJA PERIMETRAL PLAYA

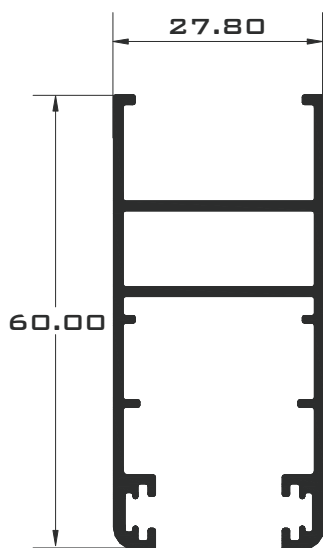

4606 HOJA PERIMETRAL DOBLE VIDRIO

ESCALA 1:1

LONGITUD: 6.10 mts.



CORREDERA SERIE 4600

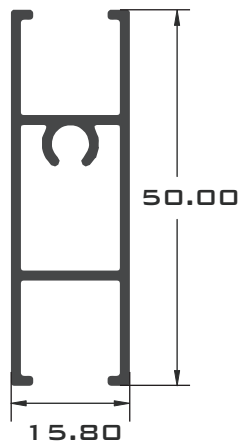

4607 INTERMEDIO

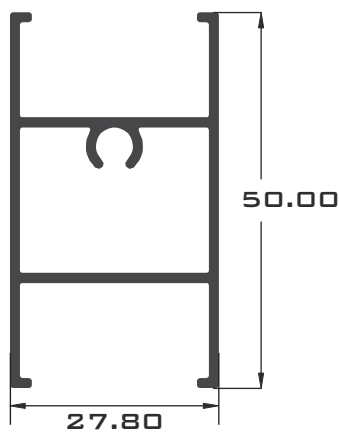

4608 INTERMEDIO DOBLE VIDRIO

ESCALA 1:1

LONGITUD: 6.10 mts.



CORREDERA SERIE 4600

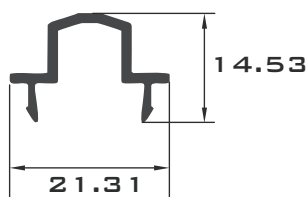

4609 UNION 4 HOJAS

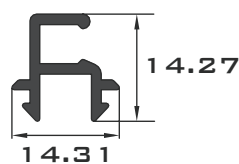

4610 ADAPTADOR MOSQUITERO

ESCALA 1:1

LONGITUD: 6.10 mts.



CORREDERA SERIE 4600

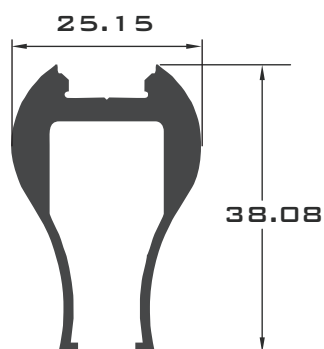

4611 TIRADOR REFUERZO

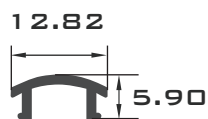

4612 TAPA PARATIRADOR REFUERZO

ESCALA 1:1

LONGITUD: 6.10 mts.



DETALLE ENSAMBLE

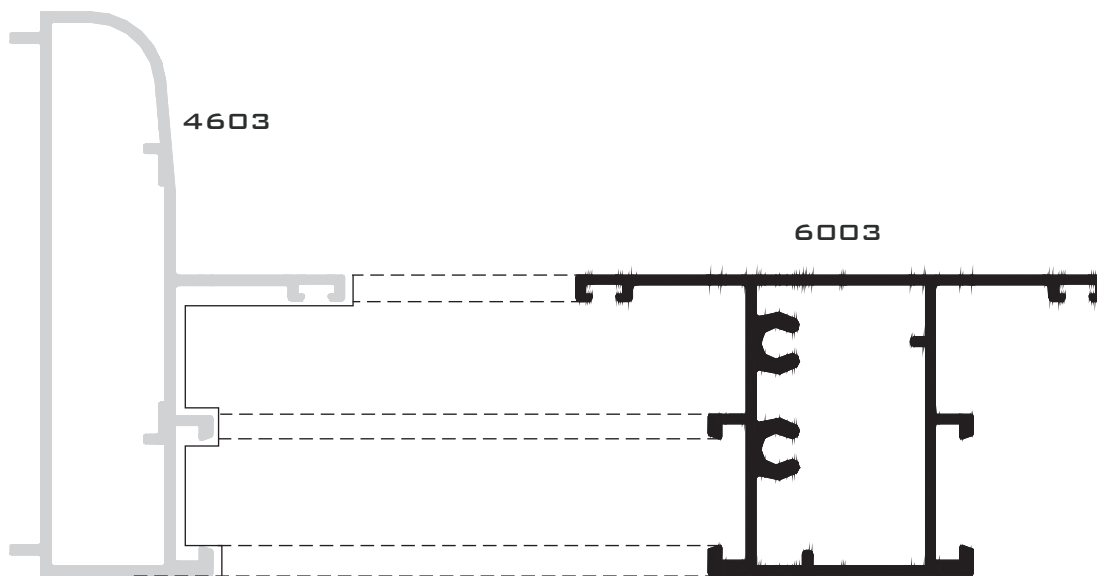
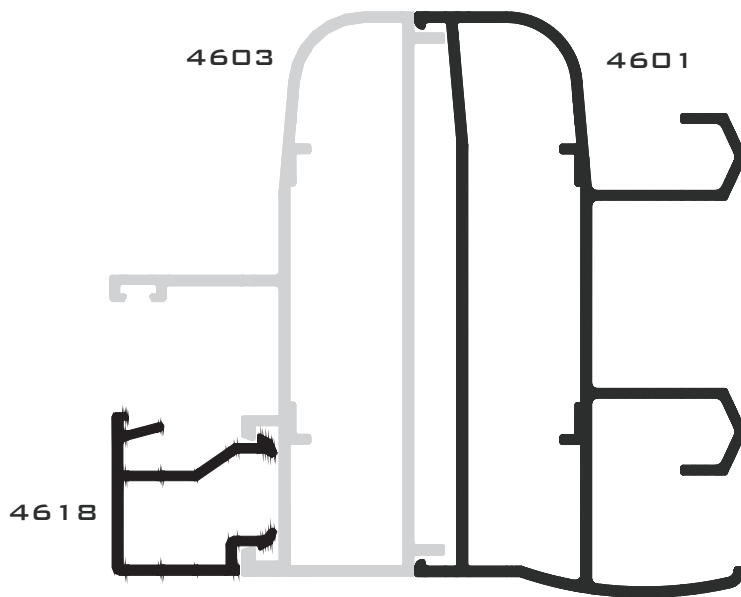

ESCALA 1:1

LONGITUD: 6.10 mts.



DETALLE ENSAMBLE

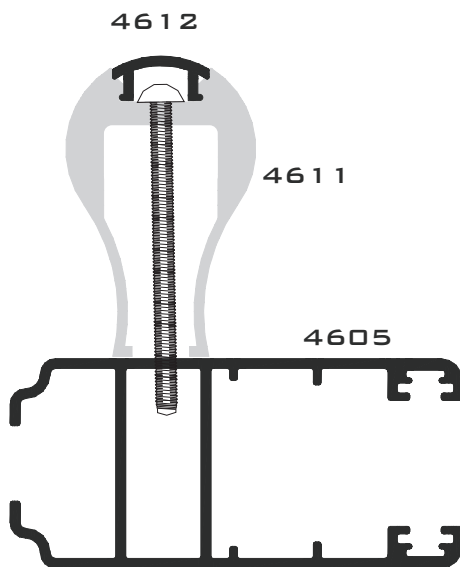
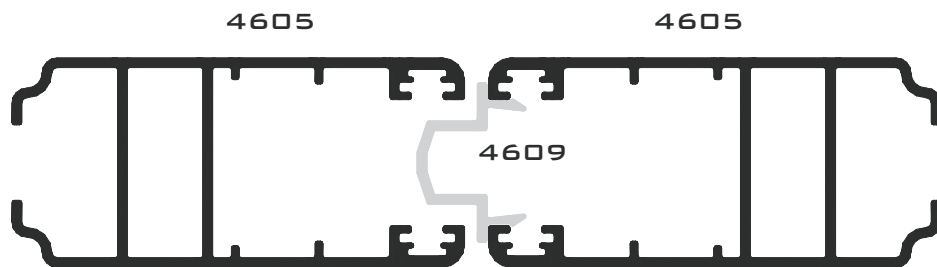

ESCALA 1:1

LONGITUD: 6.10 mts.



DETALLE ENSAMBLE

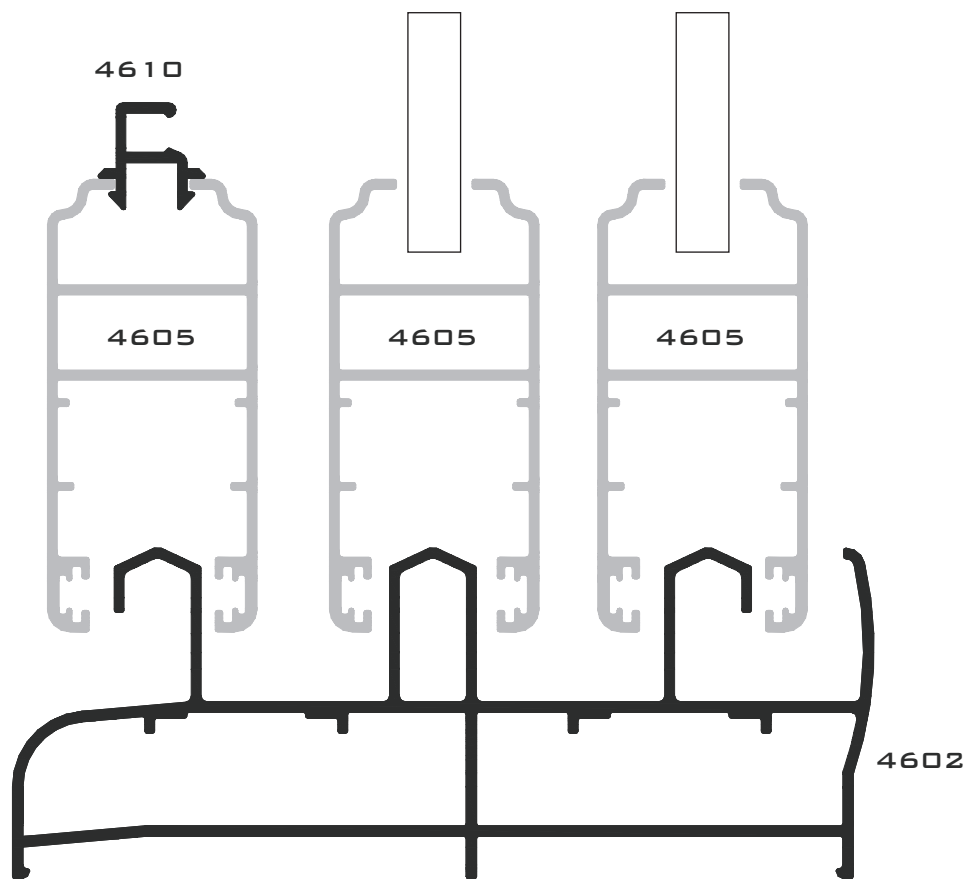

ESCALA 1:1

LONGITUD: 6.10 mts.



DETALLE ENSAMBLE

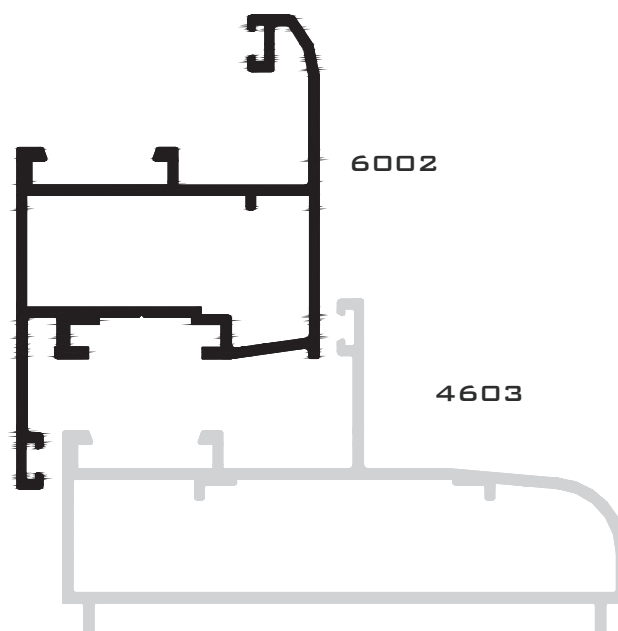
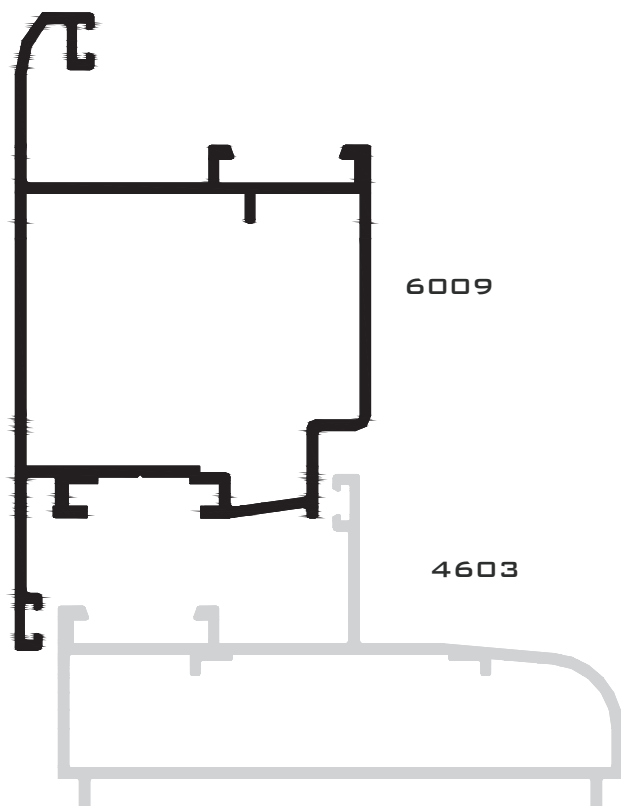

ESCALA 1:1

LONGITUD: 6.10 mts.



VENTANA Y PUERTA

2 HOJAS SERIE 4600

CORREDERA 2 HOJAS

DESCRIPCION	CLAVE	CORTE	DIBUJO	CANTIDAD	MEDIDAS EN MM.
CERCO PERIMETRAL	4601	45°		2	A
CERCO PERIMETRAL	4601	45°		2	B
HOJA PERIMETRAL	4605	45°		4	A - 73
HOJA PERIMETRAL	4605	45°		4	B / 2 - 7
*HOJA PERIMETRAL	4605	45°		8	A - 73
*HOJA PERIMETRAL	4605	45°		8	B + 58 / 4
*UNION 4 HOJAS	4609	90°		1	A - 73
TAPETA HOJA CENTRAL	4604	90°		2	A - 73
CIERRE EMBUTIDO	7150			2	
CARRETILLA GRADUABLE	7152-0			4	
KIT PERIMETRAL	7151-7			1	
ESCUADRA HOJA	1326-0			8	
ESCUADRA CERCO	1328-0			4	
METROS FELPA 7X6	3206-0				S/MEDIDAS

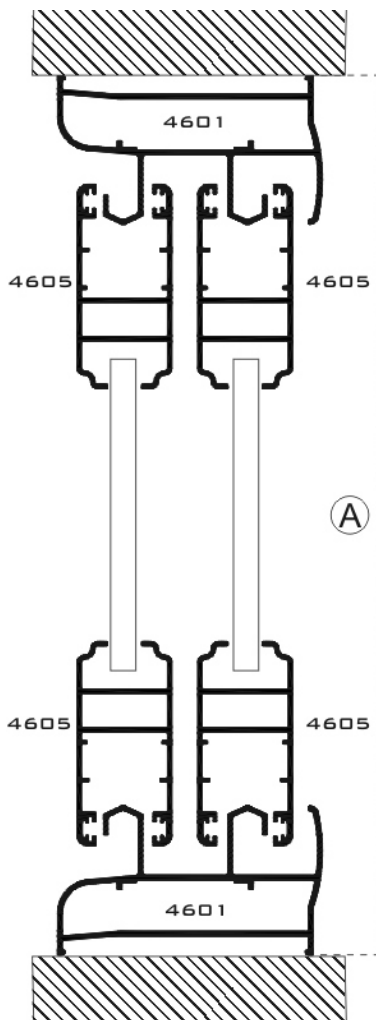

*NOTA: DESCUENTO PARA 4 HOJAS

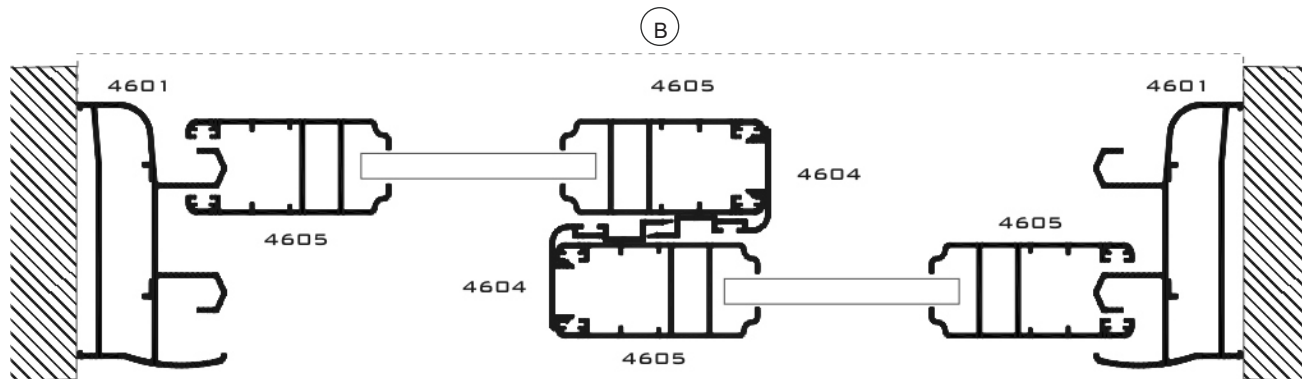



VENTANA Y PUERTA

3 HOJAS SERIE 4600

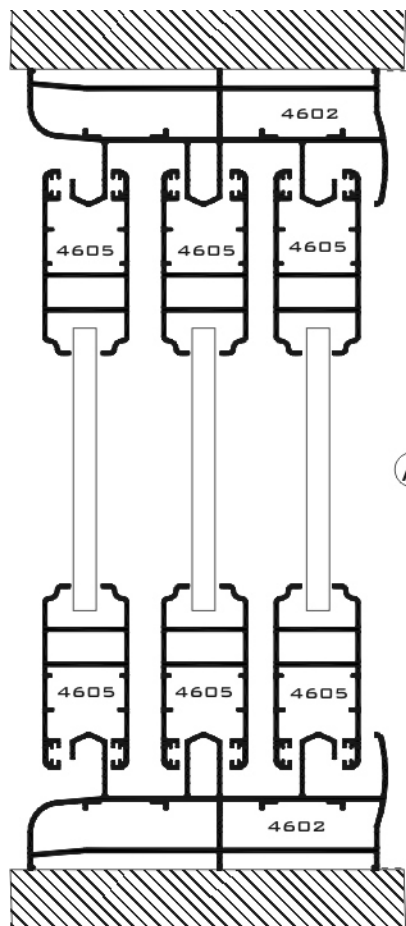

CORREDERA 3 HOJAS 3 RIELES					
DESCRIPCION	CLAVE	CORTE	DIBUJO	CANTIDAD	MEDIDAS EN MM.
CERCO PERIMETRAL	4602	45°		2	A
CERCO PERIMETRAL	4602	45°		2	B
HOJA PERIMETRAL	4605	45°		6	A - 73
HOJA PERIMETRAL	4605	45°		6	B + 54 / 3
TAPETA HOJA CENTRAL	4604	90°		4	A - 73
CIERRE EMBUTIDO	7150			2	
CARRETILLA GRADUABLE	7152-0			6	
KIT PERIMETRAL	7151-7			2	
ESCUADRA HOJA	1326-0			12	
ESCUADRA CERCO	1327			8	
METROS FELPA 7X6	3206-0			S/MEDIDAS	

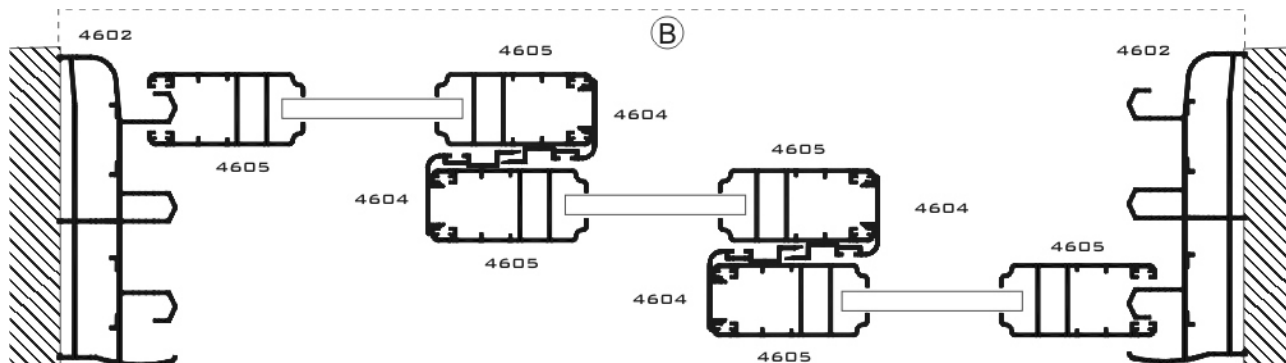



GRAFICA DE RESISTENCIA AL VIENTO

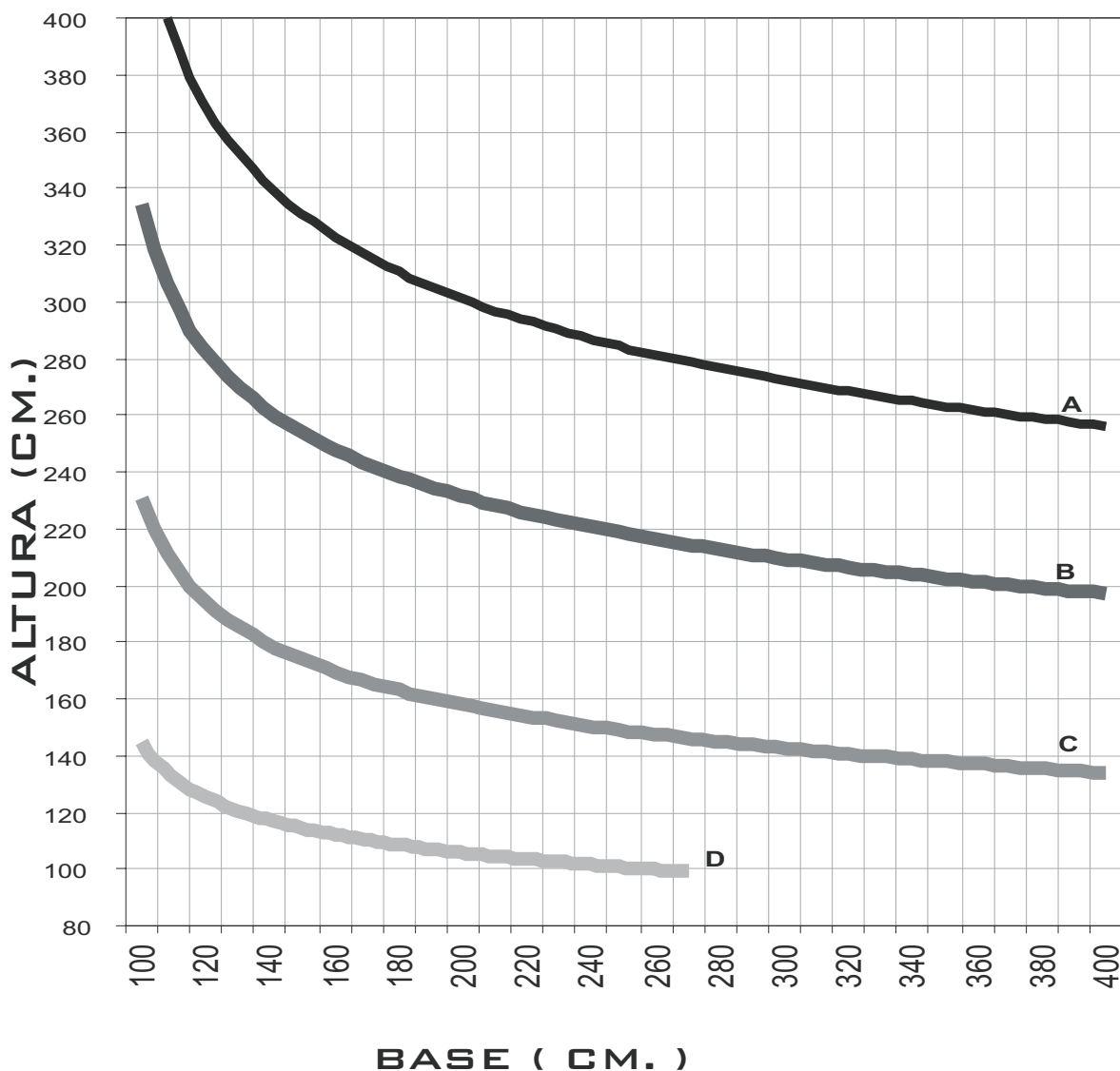

Calculo basado en un edificio de 15 Mts. de altura

A: Grandes Ciudades 92 Km/h B: Zona Residencial 115 Km/h
C: Campo Abierto 145 Km/h D: Zona Costera 213 Km/h

La Resistencia al Viento esta basada en los Perfiles y Herrajes que componen la ventana o puerta.



**Extrusiones
Metálicas**

SERIE 4600

**ARMADO
DETALLE DE**

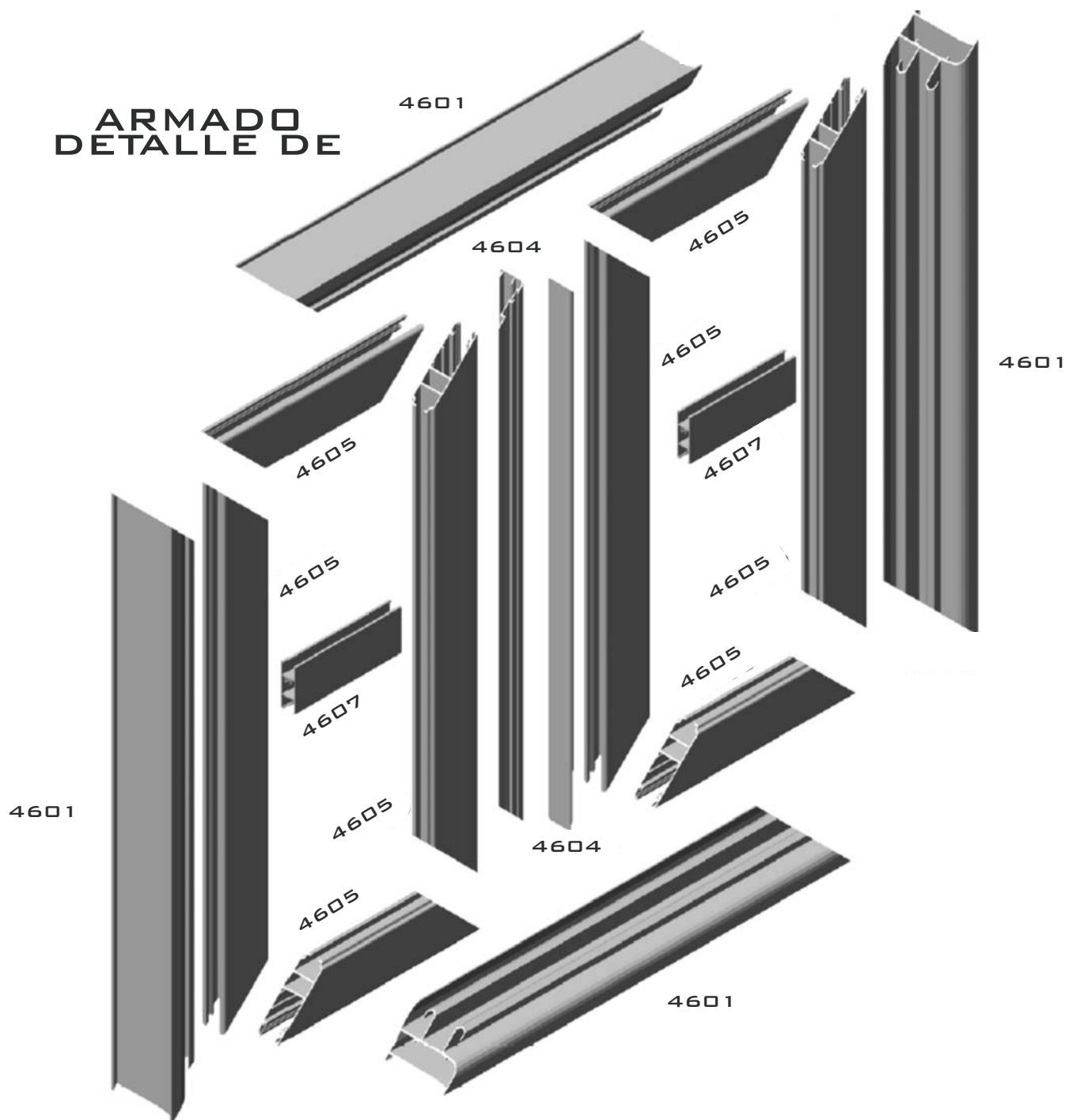



TIPOS DE APERTURAS

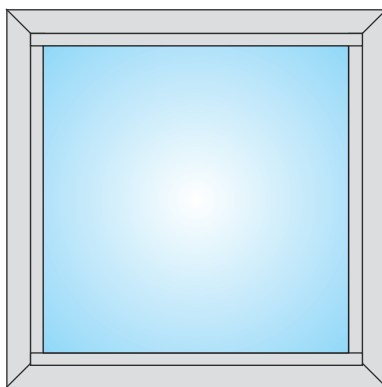

FIJO

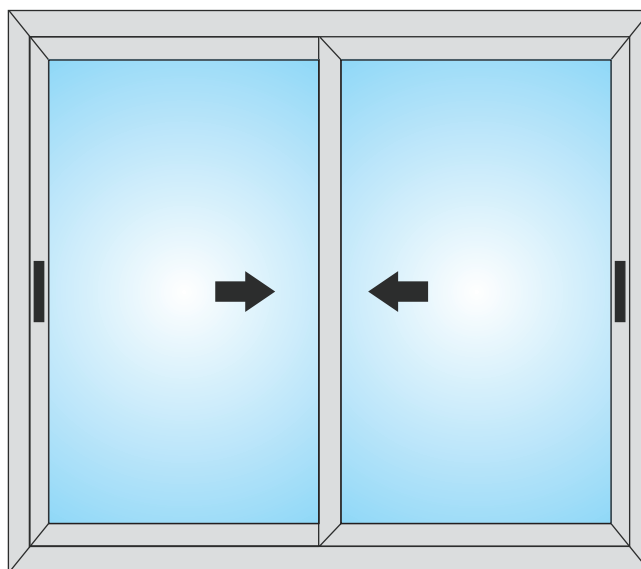

CORREDERA 2 HOJAS



TIPOS DE APERTURAS

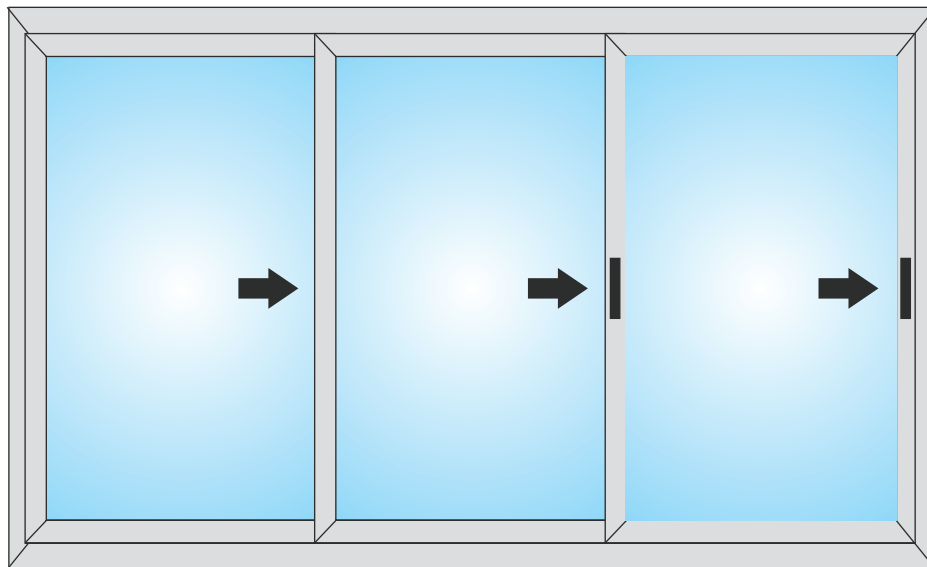

CORREDERA 3 HOJAS

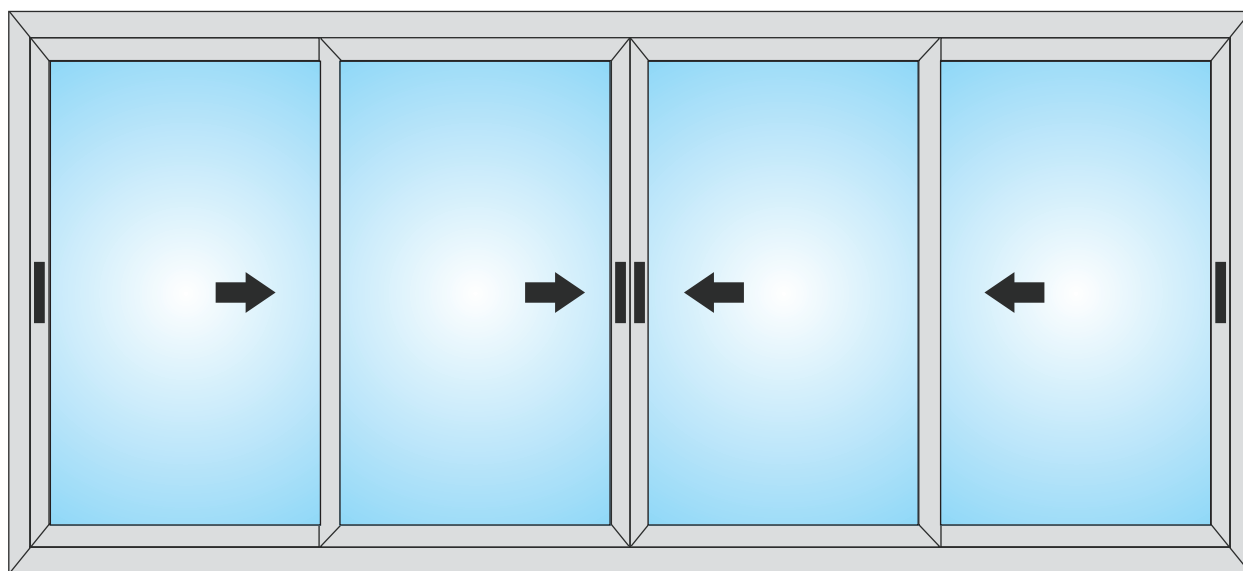

CORREDERA 4 HOJAS